

# SMOKY LAKE COUNTY



<b>Title: Approaches</b>	<b>Policy No: 05-05</b>
<b>Section: 03</b>	<b>Page No.: 1 of 6</b>

<b>Legislative Reference:</b>	Alberta Provincial Statutes
-------------------------------	-----------------------------

<b>Purpose:</b>	To establish consistent practice for all approach construction in Smoky Lake County as well as provide an application for all new approach installation.
-----------------	--

## Policy Statement and Guidelines:

### 1. STATEMENT

Smoky Lake County, being the road authority, must ensure that private approaches are situated at locations that are considered safe and are constructed to approved standards so as not to endanger the safety of the public.

### 2. GUIDELINES

The following considerations will be applicable for all access approach requests:

- 2.1 The construction of the first or additional access approach will only be granted where the requested location is considered practical and safe in the sole discretion of the County.
- 2.2 Where a subdivision parcel exists adjacent to an internal subdivision road and also borders on an external grid road, consideration will only be given to a possible additional access approach to the internal subdivision road.
- 2.3 An application to construct a new access approach to replace an existing approach may be approved by the County.
- 2.4 All requests for access off a Provincial Highway must be submitted to Alberta Transportation for review and approval.

### 3. REGULATIONS

#### 3.1 Rural:

- 3.1.1 Where there is no approach to an un-subdivided quarter section of land used or proposed for agricultural or residential use, and where there is an existing developed municipal roadway adjacent to the land; the County will, upon request by the landowner, construct one access approach to the land to normal County standards at no cost to the landowner.
- 3.1.2 Lands containing an oil/gas industry lease road approach constructed from an adjacent municipal road shall be deemed to have an access approach and the County will not provide for any additional approaches under section 3.1.1 above.

<b>Title: Approaches</b>	<b>Policy No: 05-05</b>
<b>Section: 03</b>	<b>Page No.: 2 of 6</b>

**Policy Statement and Guidelines:**

- 3.1.3 The County may grant approval for the landowner to construct an additional access approach to an un-subdivided quarter used for agricultural or residential purposes.
- 3.1.4 For parcels of land that have been previously subdivided and there is no approach to the new parcel, the County will not construct an access approach to the land.
- 3.1.5 **Approach location** must have a minimum of 600 feet (180 m) sight distance each way.
- 3.1.6 **Finished Approach Top** must be 28 feet (8.53 m) in width (minimum) and flared to the County road, measured at top of the road surface, above the culvert.
- 3.1.7 **A Culvert**, when required, must be corrugated steel plastic (CSP) culverts and be the following diameters or as otherwise directed by the Public Works Manager or designate:
  - 3.1.7.1 Culvert diameter requirement will be determined upon inspection with a **minimum** diameter of 300 mm (12”).
  - 3.1.7.2 Culvert length must be 32.8 feet (10 m) **minimum**.

**3.2 Urban / Multi-Lot Country Residential:**

- 3.2.1 For any parcels in a hamlet or multi-lot country residential land which are bordered by a lane as well as a street, the County will permit the landowner to construct access to the land at his/her own cost, a maximum of one access to the street and a maximum of one access to the lane.
- 3.2.2 **Finished Approach Top** must be 20 feet (6.10 m) in width (minimum) and flared to the County road, measured at top of the road surface, above the culvert.
- 3.2.3 **A culvert**, when required, must be corrugated steel plastic (CSP) culverts and be the following diameters or as otherwise directed by the Public Works Manager or designate:
  - 3.2.3.1 Culvert diameter must be 300 mm (12”) **minimum**.
  - 3.2.3.2 Culvert length must be 24 feet (7.3 m) **minimum**.

**Policy Statement and Guidelines:**

**3.3 Other:**

3.3.1 For lands on which oil and / or gas facilities are located or proposed to be located, approach applications by oil and gas companies will be administered by the County according to **Policy Statement 09-11: Oilfield Permit / Inspection Fee.**

**4. APPROACH CONSTRUCTION**

- 4.1 The approach must have a reasonable slope, not exceeding 5% for a distance of 50 feet (15 meters) away from the County road into the parcel.
- 4.2 Base material must be used prior to gravelling and must be properly compacted in lifts, no deeper than 10 inches.
- 4.3 Suitable common fill material (e.g. clay or pitrun) must be used.
- 4.4 Approach surface must be graveled with a minimum of ten cubic yards of 25 mm (1 inch) crushed gravel or “sufficient material” that meets the approval of the County Public Works Manager or Public Works Foreman. Approaches constructed onto local or subdivision gravel, cold mix or hot mix surfaces shall not require asphalt, or any kind of treatment. Property owner is responsible to maintain approach.
- 4.5 Culverts must be installed in the base of the ditch within the road allowance and be of sufficient minimum length as referenced herein.
- 4.6 Approach Construction Detail - as indicated below:

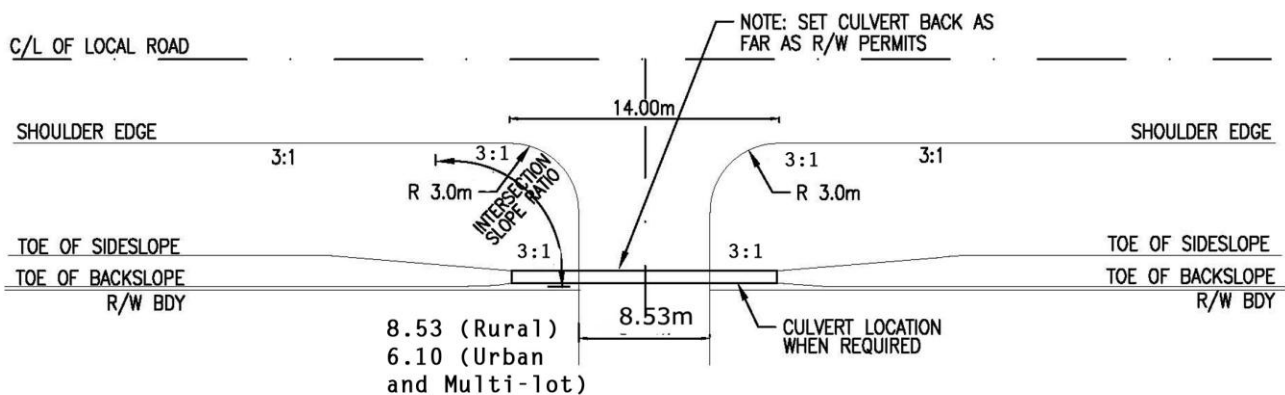

**APPROACH DETAIL**

SCALE: N.T.S.

<b>Title: Approaches</b>	<b>Policy No: 05-05</b>
<b>Section: 03</b>	<b>Page No.: 4 of 6</b>

<b>Policy Statement and Guidelines:</b>	
<b>5. PROCEDURES:</b>	
5.1	All requests for the construction of an Approach(es) <i>except</i> those referenced in Section 3.1.1 herein or for approach constructions subject to Sub-division Development Agreements, are required to complete <b>Schedule "A": APPLICATION FOR APPROACH CONSTRUCTION</b> Form.  <b><u>No other Development Permit Form shall be required.</u></b>
5.2	Application must be completed and submitted to the County Office, accompanied with a fee of \$50.00 (fifty) dollars.
5.3	All approaches constructed by a landowner, or his/her contractor shall be at the sole cost of the landowner.
5.4	If requesting the County to construct the approach(es) for the Applicant, a fee of <b>\$3,000.00 (three thousand dollars)</b> , per approach, must be submitted with the Application.
5.5	Upon review and evaluation of the application, the County will advise the Applicant of refusal or approval of the application.
5.6	When the County is requested to build the approach, and in the case of application refusal, or inability for the County to construct the approach, the construction fee will be refunded to the Applicant within 30 (thirty) days.
5.7	Any approval issued or inspection completed by the County may include conditions requiring alterations to the proposed location and / or standards of construction may require additional fee from the landowner, based on the additional current material costs in cases where the County has been requested to construct the approach.
5.8	Any approach applications approved under this policy shall be valid for <b>1 (one) year</b> from date of approval, excluding approaches required as part of a Subdivision Application, and may be extended upon written request from the landowner to the County.

	<b>Date</b>	<b>Resolution Number</b>
<b>Approved</b>	<b>June 20, 1991</b>	<b># 849 - Page # 5331</b>
<b>Approved</b>	<b>September 28, 2000</b>	<b># 643 - Page # 6931</b>
<b>Amended</b>	<b>May 23, 2002</b>	<b># 381 - Page # 7294</b>
<b>Amended</b>	<b>September 20, 2007</b>	<b># 610-07 - Page # 8478</b>
<b>Amended</b>	<b>December 16, 2011</b>	<b># 172-11 - Page # 9915</b>

**SCHEDULE "A"**



Box 310 4612 McDougall Drive  
 Smoky Lake, AB T0A 3C0  
 Phone: 888.656.3730 Fax 780.656.3768

**APPLICATION  
 FOR APPROACH  
 CONSTRUCTION**

APPLICANT INFORMATION			COMPLETE IF DIFFERENT FROM APPLICANT		
NAME OF APPLICANT			NAME OF REGISTERED OWNER		
MAILING ADDRESS			MAILING ADDRESS		
POSTAL CODE	TELEPHONE (RES)	OTHER	POSTAL CODE	TELEPHONE (RES)	OTHER

LAND INFORMATION								
LEGAL DESCRIPTION								
QTR/LSD	SECTION	TOWNSHIP	RANGE	W4	OR	REGISTERED PLAN	BLOCK	LOT
REASON FOR CHANGING OR REQUESTING APPROACH								

I hereby make application to construct an approach in accordance with the attached plan and specifications and at the location shown on the sketch plan on reverse of this form.

\_\_\_\_\_  
 DATE OF APPLICATION

\_\_\_\_\_  
 SIGNATURE OF APPLICANT

**INCLUDE WITH THIS APPLICATION:**

- Application Fee of \$50.00.**
- \$3,000.00, per approach,** if requesting the County to construct the approach(es).

**NOTES:**

1. Each parcel of land can normally only have one approach for access. An additional approach is subject to approval by Smoky Lake County and will be constructed by the owner at his own cost, to a standard acceptable to the County.
2. Applicant is agreeing to allow the Public Works Department to perform with pre and post construction inspections.

The personal information provided by you is being collected under the authority of the Municipal Government Act and will be used for the purposes under that Act. The personal information that you provide may be made public, subject to the provisions of the *Freedom of Information and Protection of Privacy Act*.

## SITE PLAN

**The sketch plan should indicate the following:**

1. Boundaries of the affected parcel including dimensions.
2. All drainage courses.
3. Proposed location of the new approach dimensioned from the closest property corner.
4. All roads adjacent to the parcel.
5. Location of the any existing approach(es).



OFFICE USE ONLY		
DATE APPROVED	COUNTY REPRESENTATIVE	FEE FOR COUNTY TO CONSTRUCT <b>\$3,000.00 / approach</b>
SPECIAL PROVISIONS		PAYMENT RECEIVED
PRE CONSTRUCTION INSPECTION DATE ACCEPTED & INITIALS	POST CONSTRUCTION INSPECTION DATE ACCEPTED & INITIALS	RECEIPT NUMBER