

SMOKY LAKE COUNTY

AGENDA: MUNICIPAL PLANNING COMMISSION to be held on

June 15, 2021 at 2:00 p.m.

Virtually, via Zoom Platform –

Virtually, Online through Zoom:

<https://us02web.zoom.us/j/88664978745?pwd=MThTbm11MmpNUTduY0hCVUJmUXhQdz09> Or,

by phone: 1-877-853-5257, Meeting ID: 886 6497 8745 Password: 966350

1. CALL TO ORDER

2. AGENDA

3. MINUTES

3.1 Adopt Minutes of May 28, 2021.

4. REQUEST FOR DECISION

4.1 **Development Permit(s) to be Considered:**

4.1.1 DP 026-21: Freestanding Signage

5. ISSUES FOR INFORMATION

5.1 Nil.

6. CORRESPONDANCE

6.1 Nil.

7. DELEGATON(S)

7.1 Nil.

8. ADJOURNMENT

SMOKY LAKE COUNTY

Minutes of the **Municipal Planning Commission** meeting from **Friday, May 28, 2021**, held in County Council Chambers and Virtually online through Zoom Meeting.

The meeting was called to Order at 11:47 a.m. by the Chairperson: Councillor Lorne Halisky in the presence of the following persons:

PRESENT

Dan Gawalko	Councillor Div. 1	Present in Chambers
Johnny Cherniwchan	Councillor Div. 2	Present in Chambers
Craig Lukinuk, Reeve	Councillor Div. 3	Present in Chambers
Lorne Halisky	Councillor Div. 4	Present in Chambers
Randy Orichowski, Deputy Reeve	Councillor Div. 5	Present in Chambers
Gene Sobolewski	CAO	Present in Chambers
Lydia Cielin	Assist. CAO	Absent
Jordan Ruegg	P&D Manager	Present in Chambers
Kyle Schole	P&D Assistant	Virtually Present
Patti Priest	Recording Secretary	Virtually Present

No Members of the Public were virtually present.

No Member of the Media was present: Smoky Lake Signal.

2.0 ADOPTION OF AGENDA

MPC21.020: Lukinuk

That the Agenda for the Municipal Planning Commission meeting for Friday, May 28, 2021, be adopted as amended.

Addition to the Agenda:

1. Smoky Lake County Owned Land within Village of Vilna - Plan 6375KS Block A Lot P.

CARRIED UNANIMOUSLY.

3.0 MINUTES

MPC21.021: Gawalko

That the Minutes of Municipal Planning Commission meeting held on Friday, April 23, 2021, be adopted as presented.

CARRIED.

4.0 REQUEST FOR DECISION

4.1 Development Permits to be Considered:

4.1.1 DP 020-21: Shipping Container

MPC21.022: Orichowski

That the Municipal Planning Commission APPROVE Development Permit No. 020-21: **PLAN 0320630, BLOCK 1, LOT 40** for the placement of a **Shipping Container (20' x 8')**, subject to the following conditions:

1. The proposed Development shall be sited as per the following minimum setbacks:
 - a. Front Yard Setback: 25.0 feet.
 - b. Rear Yard Setback: 25.0 feet.
 - c. Side Yard Setbacks: 5.0 feet.
2. The Developer shall obtain any and all necessary approvals, permits, authorizations and licenses from any and all agencies, departments and authorities as may be required.
3. Any Development involving pipeline and/or powerline rights-of-way shall be sited to comply with all relevant federal and provincial legislation and regulations. Setbacks from pipelines and other utility corridors shall be in accordance with appropriate provincial legislation and regulations and any regulations established by the Alberta Energy and Utilities Board.

4. The Shipping containers shall not be stacked.
5. The maximum height for the shipping container shall be 3.0 m (10.0 ft.).
6. The maximum length for the shipping container shall be 6.0 m (20.0 ft.).
7. Lot grade elevations must ensure that site grades shall be established to not allow one site to drain onto an adjacent site.
8. The exterior finish of the shipping container must be complimentary with the finish of the primary building. The finish shall be made consistent with the finish of the primary building within two (2) years of the date of issuance of this Development Permit.
9. The shipping container shall not be used as a dwelling, bunk house or a guest house without first applying for and obtaining a valid Development Permit for that use.
10. No human or animal habitation will be permitted within the shipping container.
11. The County reserves the right to inspect the site for non-compliance.

CARRIED UNANIMOUSLY.

4.1.2 DP 023-21: Shipping Container

MPC21.023: Lukinuk

That the Municipal Planning Commission APPROVE Development Permit No. 023-21: **PLAN 7821750, BLOCK 3, LOT 6** for the placement of a **Shipping Container (20' x 8')**, subject to the following conditions:

1. The proposed Development shall be sited as per the following minimum setbacks:
 - a. Front Yard Setback: 25.0 feet.
 - b. Rear Yard Setback: 25.0 feet.
 - c. Side Yard Setbacks: 5.0 feet.
2. The Developer shall obtain any and all necessary approvals, permits, authorizations and licenses from any and all agencies, departments and authorities as may be required.
3. Any Development involving pipeline and/or powerline rights-of-way shall be sited to comply with all relevant federal and provincial legislation and regulations. Setbacks from pipelines and other utility corridors shall be in accordance with appropriate provincial legislation and regulations and any regulations established by the Alberta Energy and Utilities Board.
4. The Shipping containers shall not be stacked.
5. The maximum height for the shipping container shall be 3.0 m (10.0 ft.).
6. The maximum length for the shipping container shall be 6.0 m (20.0 ft.).
7. Lot grade elevations must ensure that site grades shall be established to not allow one site to drain onto an adjacent site.
8. The exterior finish of the shipping container must be complimentary with the finish of the primary building. The finish shall be made consistent with the finish of the primary building within two (2) years of the date of issuance of this Development Permit.
9. The shipping container shall not be used as a dwelling, bunk house or a guest house without first applying for and obtaining a valid Development Permit for that use.
10. No human or animal habitation will be permitted within the shipping container.

CARRIED UNANIMOUSLY.

Municipal Planning Commission Meeting Reschedule

MPC21.024: Lukinuk

That the Municipal Planning Commission meeting scheduled for Friday, May 28, 2021 at 1:00 p.m., be rescheduled for Friday, May 28, 2021 at 11:45 a.m., to be held virtually and/or physically in County Council Chambers.

CARRIED UNANIMOUSLY.

ADDITION THE AGENDA:

Smoky Lake County Owned Land within Village of Vilna - Plan 6375KS Block A Lot P

MPC21.024: Gawalko

That the Municipal Planning Commission recommend Smoky Lake County's Planning and Development Department submit a letter to the Village of Vilna to bring awareness to the building encroachment onto the County owned land legally described as Plan 6375KS Block A Lot P, within the Village of Vilna; and to collaborate a solution of a possible land transfer to the Village of Vilna.

CARRIED UNANIMOUSLY.

5.0 ISSUES FOR INFORMATION

5.1 Nil.

6.0 CORRESPONDENCE

6.1 Nil.

7.0 DELEGATION

7.1 Nil.

8.0 ADJOURNMENT

MPC21.024: Halisky

That the Municipal Planning Commission Meeting of May 28, 2021, adjourn at 12:18 p.m.

CARRIED.

Lorne Halisky, Chairperson

S E A L

Gene Sobolewski, CAO

**MUNICIPAL PLANNING COMMISSION
DEVELOPMENT REPORT**



AGENDA ITEM 4.1.1

MEETING DATE	JUNE 15, 2021
FILE NO.	DP 026-21
LEGAL DESCRIPTION	LOT 13, VICTORIA SETTLEMENT (PT. 13-58-17-W4M)
LOT AREA	+/- 77.92 ACRES (31.53 HA)
APPLICANT	GENMEC ACL INC.
LANDOWNER	METIS CROSSING LTD.
PROPOSED DEVELOPMENT	PLACEMENT OF TWO (2) FREESTANDING WELCOME SIGNS (SIGN DIMENSIONS = 12'-4 ¹ / ₂ " TALL X 10'-0 ¹ / ₂ " WIDE).
ZONING	VICTORIA COMMERCIAL (C2) DISTRICT
DEVELOPMENT TYPE	PERMITTED USE – VARIANCE REQUIRED
ROLL NO.	17581350
DIVISION	3

RECOMMENDATION

That the Municipal Planning Commission approve Development Permit No. 026-21: LOT 13, VICTORIA SETTLEMENT (PT. 13-58-17-W4M), for the **placement of two freestanding welcome signs, requiring a variance of the maximum allowable sign area from 8.0 square metres (86.11 square feet) to 10.76 square metres (115.89 square feet)**, subject to the following conditions:

1. The proposed signage shall be developed and sited as per the drawings, labelled as “Metis Crossing Highway Signs”, dated April 29, 2021, attached to, and forming part of, this Development Permit.
2. The Developer shall be required to obtain from Alberta Transportation, and comply with the conditions of, a Roadside Development Permit.
3. The minimum setback distance of the proposed signs from the right-of-way of Highway 855 shall be determined by the Roadside Development Permit issued by Alberta Transportation pursuant to Condition #2 of this Development Permit.
4. The minimum setback distance of the proposed signs from Victoria Trail (TWP RD 581A) shall be 7.6 metres (25.0 feet).
5. The maximum allowable face area of each of the proposed signs shall be 10.76 square metres (115.89 square feet).
6. The proposed signage shall not be affixed to, or located on, any public property without the prior written consent of the appropriate public body.
7. The proposed signs shall not project within 0.6 metres (1.9 feet) of a property line or within 2.0 metres (6.56 feet) of overhead utility lines.
8. The proposed signage shall not resemble or conflict with a traffic control sign, nor shall the proposed signage be a traffic hazard.
9. The Development Authority reserves the right to remove any sign that, in the opinion of the Development Authority, is unsightly or in such a state of disrepair as to constitute any other kind of hazard.
10. The proposed signage shall be of such size and design so as to not, in the opinion of the Development Authority, obstruct the vision of persons using roads abutting the parcel.
11. The proposed signage shall not have flashing nor animated components.
12. The area around the proposed signage shall be kept clean and free from overgrown vegetation and free from refuse material.

13. All applicants, private and general contractors shall, during construction and placement of the proposed signage, keep the land in a reasonable condition so as not to constitute a nuisance, and shall secure all manner of debris so as to prevent it from blowing onto any other private or public property. At the conclusion of construction, all building materials and debris shall be cleared from the site. As well the Developer shall prevent excess soil and debris from being spilled onto public road allowances, streets, lanes and sidewalks.
14. The Developer shall be responsible during construction and placement of the proposed signage for any and all damages caused by the Developer, his servants, his suppliers, his agents or his contractors, to any public or private property.

BACKGROUND

1. The reason this application is being referred to MPC is that the requested variance of the maximum allowable sign area from 8.0 square metres (86.11 square feet) to 10.76 square meters (115.89 square feet) is in excess of 25%. Section 2.12(3) of Land Use Bylaw 1272-14 states that Development Permit applications that propose a variance of the provisions of this land use bylaw in excess of 25% will be referred by the Development Authority Officer to the Municipal Planning Commission.
2. In relation to Section 2.14 of Land Use Bylaw 1272-14: If approved, a notice of the decision and right of appeal, will be mailed to the adjacent landowners and advertised in the local newspaper.

SUPPORTING DOCUMENTS

APPENDIX A	LAND USE BYLAW NO 1272-14: SECTION 8.9: (C2) DISTRICT	PAGE 3
APPENDIX B	LAND USE BYLAW NO 1272-14: SECTION 6.16 SIGN REGULATIONS	PAGE 7
APPENDIX C	LAND USE BYLAW NO 1272-14: SECTION 2.12: POWERS OF VARIANCE	PAGE 10
APPENDIX D	MDP BYLAW NO 1249-12: SECTION 4.4: COMMERCIAL POLICY	PAGE 11
APPENDIX E	MDP BYLAW NO 1249-12: SECTION 5.1: VICTORIA OVERLAY	PAGE 12
APPENDIX F	DEVELOPMENT PERMIT APPLICATION	PAGE 13
APPENDIX G	GENERAL LOCATION MAP	PAGE 26

Prepared by: _____
 Jordan Ruegg
 Planning and Development Manager

June 10, 2021
 Date

8.9 VICTORIA COMMERCIAL (C2) DISTRICT

1. Purpose

The general purpose of this District is to control development in the vicinity of the Victoria Trail in order to ensure that future commercial development in this area is compatible with significant cultural landscapes in the Victoria Trail area.

2. Permitted Uses

- A. Art, Craft, and Photography Studios
- B. Bed and Breakfast Establishment
- C. Boutique Accommodation
- D. Buildings and Uses Accessory to Permitted Uses
- E. Campground, basic,
- F. Community Hall
- G. Convenience Retail Service
- H. Cultural Facility
- I. Drive-in Business
- J. Eating and Drinking Establishment
- K. Eco-Cabin/Star-gazing Units
- L. Extensive Agriculture
- M. Home Occupation, Minor
- N. Home Occupation, Major
- O. Natural Area
- P. Protective or Emergency Services
- Q. Public or Quasi-Public Services
- R. Public Park
- S. Secondary Suite
- T. Solar Energy Conversion System
- U. Wind Energy Conversion System, Micro

3. Discretionary Uses

- A. Amusement Establishment, Indoor
- B. Amusement Establishment, Outdoor
- C. Buildings and Uses Accessory to Discretionary Uses
- D. Campground, minor
- E. Campground, intermediate
- F. Campground, major
- G. Cemetery
- H. Commercial Uses

- I. Dwelling, Single Detached
- J. Dwelling, single detached, tiny
- K. Duplexes (Vertical and Side-By-Side)
- L. Hotel
- M. Manufactured Home
- N. Modular Home
- O. Motel
- P. Natural Resource Extraction
- Q. Outdoor Eating Establishment
- R. Places of Worship
- S. Public Utilities
- T. Recreational vehicle park
- U. Shipping Container
- V. Surveillance Suite
- W. Transfer Station
- X. Wind Energy Conversion System, Small
- Y. Other Uses which, in the opinion of the Development Authority, are similar to the above mentioned Permitted and Discretionary Uses

4. Subdivision Regulations

A. General

- i. All subdivisions in environmentally sensitive areas and significant cultural landscapes, including but not limited to the Victoria Commercial District, must be designed to retain historically significant patterns of spatial organization and significant environmental features.
- ii. The County considers river lots to be historically significant patterns of spatial organization. Therefore subdivisions within existing river lots must be designed in such a manner that the original river lot pattern is still retained.
- iii. The County will normally require new developments in areas identified as containing significant cultural landscapes, preserve a minimum of 50% of the existing vegetation on each site.
- iv. New developments will also be required to maintain, as much as possible, the current land form and to be sited in such a manner as to ensure that the current viewscape of the areas from the Trail is maintained within the nationally recognized Victoria Trail Heritage Site.

B. Minimum Lot Area – As determined by the Subdivision Authority

5. Development Regulations

A. Minimum Yard Setback Requirements

It should be noted that adjacent to Provincial Highways, Alberta Transportation may require greater setbacks for development. Contact Alberta Transportation regarding their requirements in this regard.

i. Minimum Front Yards

From Municipal Road Allowances	23.1 m (92.0 ft.) from the property line
From Highways	40.8 m (134.0 ft.) from the boundary of the right-of-way or as required by Alberta Transportation
Internal Subdivision Roads	7.6 m (25.0 ft.) from the property line

ii. Minimum Side Yards

From Municipal Road Allowances	18.3 m (60.0 ft.) from the property line
From Highways	40.8 m (134.0 ft.) from the boundary of the right-of-way or as required by Alberta Transportation
When adjacent to an Internal subdivision road	7.6 m (25.0 ft.) from the property line
When adjacent to Another Parcel	7.6 m (25.0 ft.) from the property line

iii. Minimum Rear Yards

From Municipal Road Allowances	18.3 m (60.0 ft.) from the property line
From Highways	40.8 m (134.0 ft.) from the boundary of the right-of-way or as required by Alberta Transportation
When adjacent to an internal subdivision road	7.6 m (25.0 ft.) from the property line
When adjacent to another parcel	7.6 m (25.0 ft.) from the property line

iv. Notwithstanding subsections (i), (ii), and (iii) above, where there is an intersection or sharp curve, the minimum yard requirements shown on Figures

20 and 21 of this Bylaw shall apply.

6. Other Regulations
- A. Development proposals adjacent to a primary highway shall comply with any relevant provincial regulations.
 - B. Fences shall be developed in accordance with Section 7.7 of this Bylaw.
 - C. Landscaping shall be provided in accordance with Section 6.11 of this Bylaw. Additionally the Development Authority may require the submission of additional information regarding the appearance or the proposed development with any application for development permits in this District in order to ensure that:
 - i. That the development is similar in character in appearance to development on adjacent sites; and
 - ii. That the development will be buffered, to the satisfaction of the Development Authority from the Victoria Trail and adjacent properties.
 - D. Grading and drainage of the site shall be provided in accordance with Section 7.17 of this Bylaw.
 - E. Accessory buildings shall be developed in accordance with Section 8.2 of this Bylaw.
 - F. Motels shall be developed in accordance with Section 6.22 of this Bylaw.
 - G. Places of Worship shall be developed in accordance with Section 6.29 of this Bylaw.
 - H. Natural Resource Extraction Industries shall be developed in accordance with Section 7.16 of this Bylaw.
 - I. Shipping Containers shall be developed in accordance with Section 7.31 of this Bylaw.
 - K. Solar Energy Conversion Systems shall be developed in accordance with Section 7.33 of this Bylaw.
 - L. Wind Energy Conversion Systems shall be developed in accordance with Section 2.9 of this Bylaw.

6.16 SIGN REGULATIONS

1. General Sign Regulations
 - A. All signs, erected on land or affixed to the exterior of a building or structure, require a development permit unless specifically exempted by this Bylaw.
 - B. No sign or advertising structures, requiring a development permit, shall be erected or affixed to private property without the prior consent of the property owner or tenant.
 - C. No signs, billboards or advertising structures, requiring a development permit, shall be erected or affixed to public property without the prior consent of the appropriate public body.
 - D. No signs, billboards or advertising structures shall resemble or conflict with a traffic sign, nor shall it be a traffic hazard.
 - E. The Development Authority may order removal of any sign which, in his/her opinion, is unsightly or in such a state of disrepair as to constitute any other kind of hazard.
 - F. No sign shall be of such size or design as to, in the opinion of the Development Authority, obstruct the vision of persons using roads abutting the parcel.
 - G. Quality, aesthetic character and finishing of sign construction shall be to the satisfaction of the Development Authority.
 - H. Except as otherwise specified in this Bylaw, the maximum area of any sign shall be 3 sq. m (32.29 sq. ft.).
 - I. Where, in the opinion of the Development Authority, a proposed sign in a commercial or industrial district might be objectionable to persons living in nearby residential districts, the Development Authority may impose such other regulations as they feel would protect the interests of the residents.
 - J. A flashing, animated or illuminated sign shall not be permitted where, in the opinion of the Development Authority, it might be objectionable to nearby residents or interfere with the safe movement of traffic.
 - K. The area around sign structures shall be kept clean and free of overgrown vegetation, and free from refuse material.
 - L. The Development Authority may require an engineer-approved plan prior to the issuance of a permit in order to ensure that a sign does not threaten public safety.
2. Signs in Residential Districts

- A. When a person has been granted a development permit to conduct a business or professional practice in his residence, that person may place a sign, not larger than 0.2 sq. m (2.15 sq. ft.), flat against an exterior wall of the building or on the inside of a window.
- B. Name or number signs shall have a surface area of no more than 0.3 sq. m (3.23 sq. ft.).
- C. For multiple-unit and boarding houses, one identification sign not exceeding 1.0 sq. m (10.76 sq. ft.) in area shall be allowed on each parcel.
- D. All exterior signs shall be placed flat against a building or designed as part of an architectural feature.
- E. No sign shall be permitted in a residential district except to identify a place of worship, school or other public institutions, home occupation or multiple unit residence.

3. Freestanding Signs

- A. Within all land use districts, except residential, one freestanding sign may be allowed per parcel as follows:
 - i. Where a parcel has more than 90.0 m. (295.27 ft.) of frontage, one additional freestanding sign may be erected for each additional 90.0 m. (295.27 ft.) or portion thereof.
 - ii. Where a parcel is double fronting or flanking, subsection 5.7(3)(a) applies to each frontage and/or flanking side.
 - iii. The height of a freestanding sign shall not exceed 9.0 m. (29.5 ft.) above grade.
 - iv. The face of a freestanding sign shall not exceed 8.0 sq. m (86.11 sq. ft.) in area.
 - v. A freestanding sign shall not project within 0.6 m (1.9 ft.) of a property line, or within 2.0 m (6.56 ft.) of overhead utility lines.
 - vi. The area around a freestanding sign shall be kept free of litter and overgrown vegetation.

4. Awning, Canopy and Projecting Signs

- A. In all non-residential districts, one awning, canopy or projecting sign shall be permitted for each side of the parcel which abuts a road.
- B. No awning, canopy or projecting sign shall extend more than 2.0 m (6.56 ft.) above the height of the building to which it is attached and no more than 9.0 m (29.5 ft.) above grade.
- C. No awning, canopy or projecting sign shall have a clearance less than 3.0 m (9.84 ft.) above a public right-of-way.

- D. No awning, canopy or projecting sign shall project within 1.0 m (3.3 ft) of a public road carriageway.
 - E. No awning, canopy or projecting sign shall be permitted where, in the opinion of the Development Authority, it obstructs free movement of pedestrians or vehicles or interferes with the repair of overhead utilities.
5. Wall, Fascia and Roof Signs
- A. Wall, fascia and roof signs shall be permitted in all land use districts, except residential, and shall indicate only the name and nature of the occupants of the development.
 - B. A wall, fascia or roof sign shall project no more than 0.3 m (0.98 ft) from the face of the building to which it is attached.
 - C. A wall, fascia or roof sign shall project no more than 2.0 m (6.56 ft) above the top of the wall to which it is attached and shall not exceed 9.0 m (29.5 ft) in height above grade.
6. Existing Signs
- These regulations shall not be applied to signs legally in existence at the date of the adoption of this Bylaw.

2.12 POWERS OF VARIANCE

1. In addition to the requirements of Section 2.4, when an application for a Development Permit application is submitted for a Permitted or Discretionary Use which does not comply with the provisions of the Bylaw, the Development Authority may request a statement from the applicant identifying the following:
 - A. that the applicant is aware that the proposed development requires a variance of this Land Use Bylaw, and
 - B. why the proposed development cannot satisfy the provisions of this Bylaw and therefore requires the proposed variance.
2. The Development Authority may approve or conditionally approve a permitted or discretionary use that does not conform to this Land Use Bylaw if, in the opinion of the Development Authority the proposed development would not:
 - A. unduly interfere with the amenities of the neighbourhood;
 - B. materially interfere with or affect the use, enjoyment or value of neighbouring parcels of land; and

- C. the proposed development conforms with the use prescribed for that land or building in this land use bylaw.
3. Development Permit applications that propose a variance from the provisions of this land use bylaw in excess of 25% will be referred by the Development Authority Officer to the Municipal Planning Commission.

Note: Use and density provisions cannot be varied by the Development Authority. If a proposed development does not conform to the use and density requirements within the applicable district then a Land Use Bylaw amendment will be required prior to development approval.

4.4 Commercial Policy

The intent of the Plan is to accommodate commercial facilities, primarily adjacent to the highway, secondary road systems, within established hamlets, and in appropriate locations within multi-lot recreation residential developments. Commercial developments provide a service to the agricultural community, local residents, the highway traveling public, and tourists to the region. The County will not support commercial developments that adversely affect the standard of safety or convenience, or the functional integrity of any highway or road. The Plan also recognizes that specific commercial uses may require unique site locations in order to serve the rural community.

Objective 4.4.1 To minimize the impacts of commercial activities on working landscapes and cultural landscapes

- Policy 4.4.1.1** The County shall consider proposals for commercial development:
- (a) that will not unnecessarily fragment the working landscape; and
 - (b) that do not conflict with adjacent land uses.
- Policy 4.4.1.2** Commercial uses shall be encouraged to avoid locating in areas of critical wildlife habitat wherever possible.
- Policy 4.4.1.3** Commercial uses operated as secondary uses to agricultural operations may be allowed.

Objective 4.4.2 To minimize conflicts with adjacent land uses

- Policy 4.4.2.1** Commercial development may be allowed to locate near urban areas in consultation with the affected urban area, as determined by the Development Authority.
- Policy 4.4.2.2** The Development Authority shall require the developer to construct and/or maintain an appropriate buffer, as determined by the Development Authority, between the development and nearby lands.
- Policy 4.4.2.3** Council shall encourage commercial development in hamlets if the necessary servicing requirements do not exceed the servicing capabilities of the hamlet or negatively impact the character of the hamlet.

Objective 4.4.3 To minimize municipal servicing costs associated with commercial development

- Policy 4.4.3.1** The Development Authority shall require the developer of a commercial development to identify all municipal servicing costs associated with the development. The assignment of these costs between the County and the developer will be the basis of an agreement to be entered into prior to a subdivision approval or upon the issuance of a development permit. Normally, however, all development servicing costs associated with the development will be carried by the developer.

5.1 Victoria Overlay

The Victoria overlay identifies that area within the County identified as the Victoria District National Historic Site of Canada. The Victoria District is of national historic importance because of its cultural landscapes and highly visible and intact physical attributes. The Victoria District represents an exceptional illustration in one concentrated area of major themes in Prairie settlement. Smoky Lake County recognizes the significance of this unique cultural landscape.

Policies in this section apply to those lands shown within the Victoria Overlay on the Smoky Lake County Future Land Use Map.

Objective 5.1.1 To ensure that development within the Victoria District Overlay does not negatively impact the unique cultural landscape

- Policy 5.1.1.1** The County shall not support resource extraction development proposals in areas that are known to possess unique historical and/or scientific or environmental features that would be disturbed or destroyed by resource extraction.
- Policy 5.1.1.2** The County will circulate development and subdivision applications to the Heritage Branch of the Alberta Government in order to determine if a Heritage Impact Assessment (HIA) is required as part of their application for subdivision or development.
- Policy 5.1.1.3** If a HIA is required, the developer shall be required to prepare a HIA for review by the Province and the County.
- Policy 5.1.1.4** If the HIA identifies the presence of heritage resources then the developer will be required to take appropriate mitigating measures, to the satisfaction of the appropriate provincial agency, prior to subdivision or development approval.
- Policy 5.1.1.5** The County will not support development proposals in locations within the Victoria Overlay that are known to possess unique historical and/or scientific or environmental features that would be negatively impacted or destroyed by the proposed development.

APPENDIX F DEVELOPMENT PERMIT APPLICATION

Section 61

SCHEDULE "A"

03-05

DEVELOPMENT PERMIT APPLICATION FORM

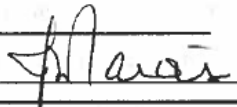
Internal Use Only	
Our File Number: _____	Roll Number: _____ Your File Number: _____
Applicant Information	
Applicant/Agent: <u>GenMec ACL Inc.</u>	Phone: <u>780-826-4450</u>
Address: <u>7301 - 50 Avenue</u>	Cell Phone: _____
City/Prov. <u>Bonnyville/AB</u> Postal Code: <u>T9N 2P3</u>	Fax: <u>780-826-2275</u>
Email address: <u>Tkress@genmecacl.com</u>	Signature: _____
<p>Applicant/Agent Authorization: I am the applicant/agent authorized to act on behalf of the registered owner and that the information given on this form is full and complete and is, to the best of my knowledge, a true statement of the facts relating to this application.</p>	
Registered Landowner Information <input type="checkbox"/> Owner same as applicant	
Registered Owner: <u>Metis Crossing</u>	Phone: <u>780-722-1993</u>
Address: <u>Box 548</u>	Fax: _____
City/Prov. <u>Smoky Lake / AB</u> Postal Code: <u>T0A 3C0</u>	Signature: 
Section A - Property Information	
Legal: Lot _____ Block _____ Plan _____ and Part of _____ ¼ Sec ^{RL 13} Twp <u>58</u> Rge <u>17</u> W4M	Division _____
Subdivision Name (if applicable) or Area of Development _____	
Rural Address/Street Address _____	Parcel Size _____
Number of existing dwellings on property (please describe) <small>One Dwelling, One Gathering Centre</small>	
Has any previous application been filed in connection with this property? <input checked="" type="checkbox"/> Yes <input type="checkbox"/> No	
If yes, please describe the details of the application and file number: <u>DP-031-20</u>	
Is the subject property near a steep slope (exceeding 15%)?	<input type="checkbox"/> Yes <input checked="" type="checkbox"/> No
Is the subject property near or bounded by a body of water?	<input type="checkbox"/> Yes <input type="checkbox"/> No
Is the subject property within 800m of a provincial highway?	<input checked="" type="checkbox"/> Yes <input checked="" type="checkbox"/> No
Is the subject property near a Confined Feeding Operation?	<input type="checkbox"/> Yes <input checked="" type="checkbox"/> No Distance: _____
Is the subject property within 1.5km of a sour gas facility?	<input type="checkbox"/> Yes <input checked="" type="checkbox"/> No Distance: _____
Is the subject property within 1.5km of a sewage treatment plant/lagoon?	<input type="checkbox"/> Yes <input checked="" type="checkbox"/> No Distance: _____
Is the subject property immediately adjacent to the County boundary?	<input checked="" type="checkbox"/> Yes <input type="checkbox"/> No
If yes, the adjoining municipality is: <u>Lamont County</u>	

Section B – Proposed Development Information

Estimated Cost of Project \$ 100,000.00

Estimated Commencement Date May 2021 Estimated Completion Date August 2021

Dwelling:

Floor Area _____ sq. ft. % of Lot Occupied _____ Height of Dwelling _____ ft / m

Accessory Building:

Floor Area _____ sq. ft. % of Lot Occupied _____ Height of Acc. Bldg _____ ft / m

Parking: # of Off-Street Parking Stalls (if applicable) _____

Land Use District (Zoning) of Property: C2 Victoria Commercial District

Description of Work:

Highway sign

Section C – Preferred Method of Communication

When a decision has been made on your file, do you wish for us to:

call you for pick up mail the decision email the decision

Section 608(1) of the *Municipal Government Act*, R.S.A. 2000, c. M-26, as amended states:

608(1) Where this *Act* or a regulation or bylaw made under this Section requires a document to be sent to a person, the document may be sent by electronic means if

- a) the recipient has consented to receive documents from the sender by those electronic means and has provided an e-mail address, website or other electronic address to the sender for that purpose.

I/we grant consent for the Development Authority to communicate information and/or the decision electronically regarding my/our application. YES NO

OFFICE USE ONLY

Type of Payment: DEBIT CASH CHEQUE

Fee \$ _____

Receipt # _____

Receipt Date _____

Date Received _____

*and deemed complete by Development Authority.

Entered into MuniSight PD # _____

Authorization:

Permitted Use Discretionary Use

Issuing Officer's Name _____

Issuing Officer's Signature _____

Date of Approval _____

Date Issued _____

Comments and/or Variances _____

DEVELOPMENT PERMIT APPLICATION FORM

Our File Number: _____	Roll Number: _____
------------------------	--------------------

DEVELOPMENT PERMIT SITE PLAN

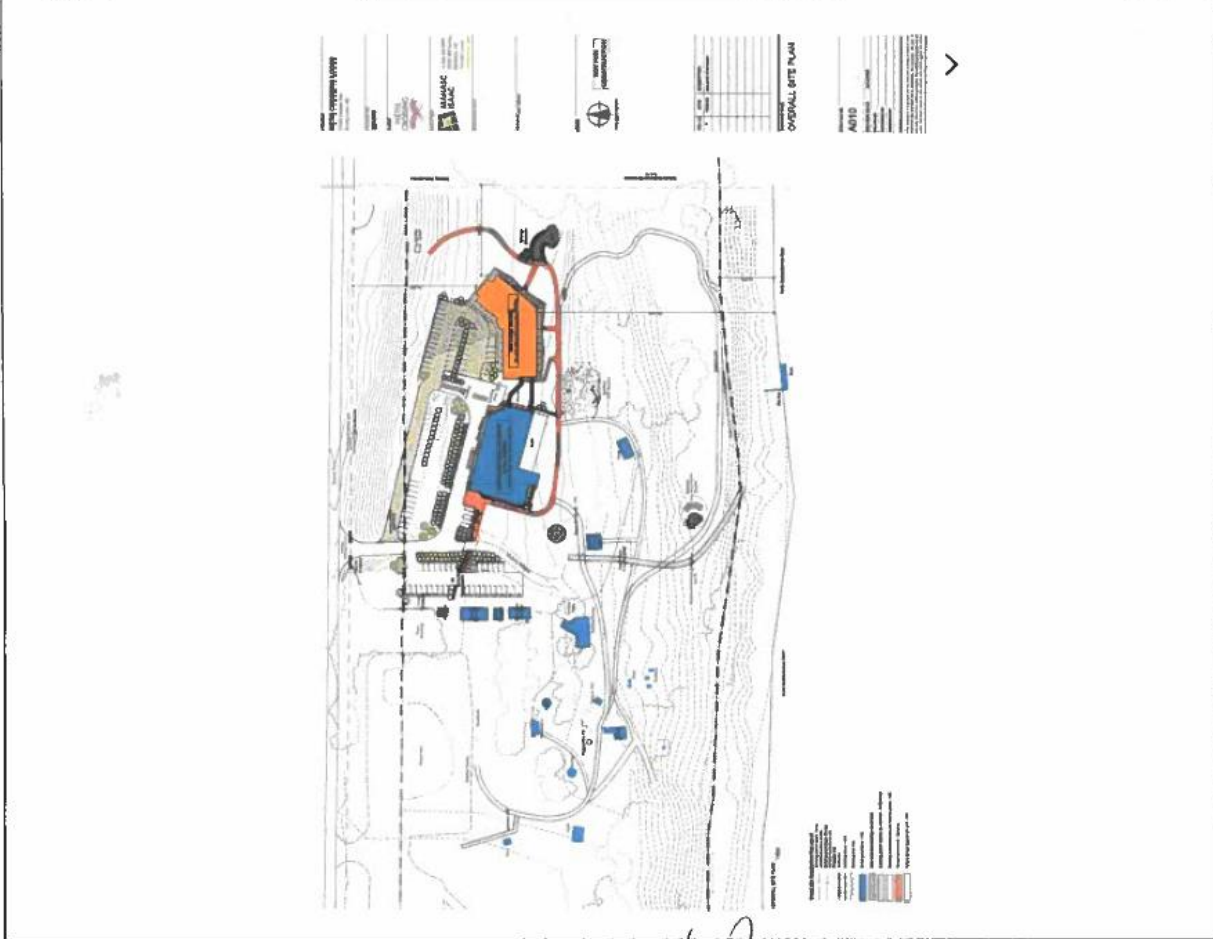

DATE: May 12, 2021	SIGNATURE OF APPLICANT: <i>[Handwritten Signature]</i>
DATE:	DEVELOPMENT AUTHORITY:

MÉTIS CROSSING Highway Signs



 BEHRENDS 2207-51 Avenue NW Edmonton, Alberta T6P 1L1 P: 780-469-5177 F: 780-467-6516 www.behrendsgroup.com	© METIS CROSSING logo, trade dress, service mark and/or trademark of the City of Edmonton. All rights reserved. No part of this drawing may be reproduced, stored in a retrieval system, or transmitted in any form or by any means, electronic, mechanical, photocopying, recording, or by any information storage and retrieval system, without the prior written permission of the City of Edmonton.	SHOP DRAWING REVIEW <input type="checkbox"/> OK - Proceed Manufacturing <input type="checkbox"/> Revision(s) Required Resubmit by (signature):	Please note: Behrends is not responsible for the accuracy of the information contained in this drawing. It is the responsibility of the client to ensure that all information is correct and that all necessary permits and approvals are obtained before construction begins.	CLIENT Métis Crossing PROJECT Highway Signs	SALES gjo DESIGN bt	DATE Apr. 29, 2021	REVISION 04	PAGE 1 of 10
	OFFICE USE ONLY: To Production: To Design: To Finance:			FILE NAME 038403.cdr				

Highway Signs
Overall Scope Only

Please Note: Please include the flag pole packages as an optional item in your quote.



North Side of Victoria Trail

Please Note: The wooden sign frames and base construction will be provided by local contractors.

South Side of Victoria Trail

Please Note: The Bison silhouettes will be added at a later date.

Signage Elevation
SCALE not to scale



BEHRENDS

2207-51 Avenue NW
Edmonton, Alberta T6P 1L1
P. 780-464-5177 F. 780-467-6516
www.behrendsgroup.com

© Behrends Group Inc. These drawings include confidential, proprietary rights of Behrends Group Inc. and are intended for use only for the project and site shown. No other use, reproduction, or distribution is permitted without the written consent of Behrends Group Inc. The contractor shall be responsible for obtaining all necessary permits and approvals for the project. The contractor shall be responsible for the accuracy of the information provided. The contractor shall be responsible for the accuracy of the information provided. The contractor shall be responsible for the accuracy of the information provided.

SHOP DRAWING REVIEW
 OK - Proceed Manufacturing
 Revisions(s) Required
 Reviewed By: [Signature]

Please review drawings carefully for accuracy and completeness. The contractor shall be responsible for the accuracy of the information provided. The contractor shall be responsible for the accuracy of the information provided.

CLIENT: Métis Crossing
PROJECT: Highway Signs

SALES: glo
DESIGN: bt
DATE: Apr. 25, 2021
REVISION: 04

OFFICE USE ONLY:
By Designer: [Signature]
Estimate Ref: 038403.cdr

PAGE: 2 of 10
FILE NAME: 038403.cdr

Highway Signs

For Overall Approximate Sizing Only



Signage Elevation
SCALE 1:30

<p>BEHREND S</p> <p>2207-91 Avenue NW Edmonton, Alberta T6P 1L3 P: 780-467-5177 F: 780-467-6516 www.behrendsgroup.com</p>	<p>SHOP DRAWING REVIEW</p> <p><input type="checkbox"/> OK - Proceed Manufacturing</p> <p><input type="checkbox"/> REVISION(S) REQUIRED</p> <p><small>Revised By: (Signature)</small></p>	<p>CLIENT Métis Crossing</p> <p>PROJECT Highway Signs</p>	<p>SALES BPO</p> <p>DESIGN bt</p> <p>DATE Apr. 29, 2021</p> <p>REVISION 04</p>	<p>PAGE 3 of 10</p> <p>FILE NAME 038403.cdr</p>
	<p><small>© Behrends Group Inc. These drawings, including all components, are the property of Behrends Group Inc. and all rights are reserved. No part of these drawings may be reproduced or transmitted in any form or by any means, electronic or mechanical, including photocopying, recording, or by any information storage and retrieval system, without the prior written permission of Behrends Group Inc. The user of these drawings agrees to hold Behrends Group Inc. harmless for any and all claims, damages, or liabilities arising out of the use of these drawings.</small></p>		<p><small>Printed on Recycled Paper. All other materials are the responsibility of the client.</small></p>	<p>OFFICE USE ONLY: No Changes No Updates No Revisions</p>

Highway Signs

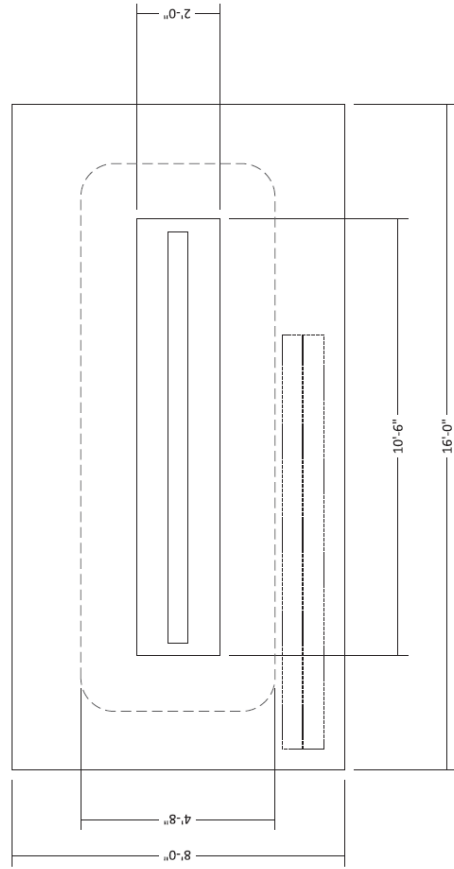
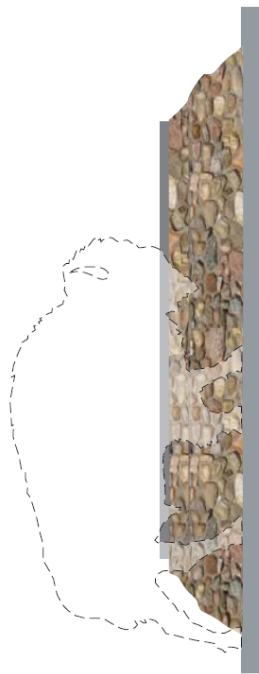

Signage Plan (top)
SCALE 1:30

<p>BEHREND</p> <p>2307-91 Avenue NW Edmonton, Alberta T6P 1L1 P: 780-464-5377 F: 780-467-6516 www.behrendsgroup.com</p>	<p>SHIP DRAWING REVIEW</p> <p><input type="checkbox"/> OK - Proceed Manufacturing <input type="checkbox"/> Revision(s) Required</p> <p>Reviewed By: (Signature)</p>	<p>CLIENT Milets Crossing</p> <p>PROJECT Highway Signs</p>	<p>SALES GJO DESIGN DT DATE Apr. 29, 2021 REVISION 04 PRICE 4 OF 10</p> <p>OFFICE USE ONLY: 30 Production: Estimate Ref: 038403.cdr</p>
--	--	--	---

Highway Signs

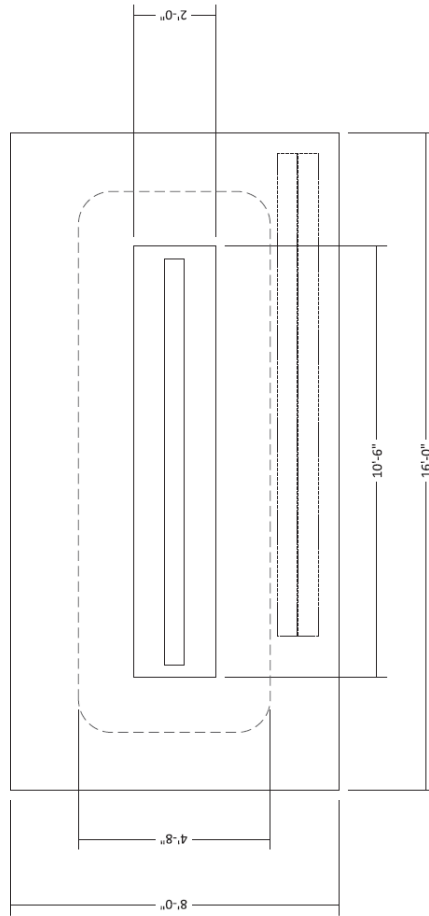

Signage Plan (top)
SCALE 1:30

220791 Avenue NW
Edmonton, Alberta T6P 1L1
P. 780-464-5177 F. 780-467-6516
www.behrendsgroup.com

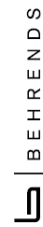

© BEHRENDS GROUP INC. These drawings, unless indicated otherwise, represent the design of the sign and are not to be used for any other purpose. The design is subject to change without notice. The client is responsible for obtaining all necessary permits and approvals for the sign. The client is responsible for the sign's location, size, and content. The client is responsible for the sign's safety and maintenance. The client is responsible for the sign's removal and disposal. The client is responsible for the sign's cost. The client is responsible for the sign's performance. The client is responsible for the sign's appearance. The client is responsible for the sign's durability. The client is responsible for the sign's visibility. The client is responsible for the sign's legibility. The client is responsible for the sign's readability. The client is responsible for the sign's understandability. The client is responsible for the sign's recognizability. The client is responsible for the sign's memorability. The client is responsible for the sign's recallability. The client is responsible for the sign's retrievability. The client is responsible for the sign's searchability. The client is responsible for the sign's accessibility. The client is responsible for the sign's usability. The client is responsible for the sign's interoperability. The client is responsible for the sign's portability. The client is responsible for the sign's scalability. The client is responsible for the sign's flexibility. The client is responsible for the sign's extensibility. The client is responsible for the sign's modifiability. The client is responsible for the sign's configurability. The client is responsible for the sign's customizability. The client is responsible for the sign's adaptability. The client is responsible for the sign's transformability. The client is responsible for the sign's convertibility. The client is responsible for the sign's interoperability. The client is responsible for the sign's portability. The client is responsible for the sign's scalability. The client is responsible for the sign's flexibility. The client is responsible for the sign's extensibility. The client is responsible for the sign's modifiability. The client is responsible for the sign's configurability. The client is responsible for the sign's customizability. The client is responsible for the sign's adaptability. The client is responsible for the sign's transformability. The client is responsible for the sign's convertibility.

SHOP DRAWING REVIEW
 OK - Proceed Manufacturing
 Revision(s) Required
 Reviewed by: [Signature]

Please review drawings carefully. Please note drawings identify the sign, the sign location, and the responsibility of the client. Date: [Date]

CLIENT
Metis Crossing
PROJECT
Highway Signs

SALES
GIO
DESIGN
bt
DATE
Apr. 29, 2021
REVISION
04
PAGE
5 of 10
OFFICE USE ONLY:
The Design:
Estimate Ref: **038403.cdr**

Highway Signs

- ITEM 1 DIMENSIONAL CUT LETTERS**
- Aluminum
 - Font: Supplied Artwork
 - Qty: 2 Sets (26 letters + 2 accents total)

- ITEM 1.A DIMENSIONAL CUT LOGO**
- Aluminum
 - Qty: 2 Sets (20 pcs total)

- ITEM 1.B SIGN PANEL COMPONENTS**
- Aluminum
 - Sign Panels Qty: 2 Sets (2 pcs total)
 - Horizontal Supports Qty: 2 Sets (6 pcs total)
 - Mounting Brackets Qty: 2 Sets (12 pcs total)

- ITEM 1.C INSTALLATION**
- Fillot High Reach 60' Crane/Bucket Truck
 - 1 Trailer & Ride Along
 - 17339 Victoria Trail, Smoky Lake, AB T0A 3C0

- ITEM 1.D MOUNTING HARDWARE**
- Stainless Steel
 - Lag Bolts Qty: 24 minimum
 - #14 Self-Tapping Qty: 78 minimum
 - Paint Hardware to Match Panel

- ITEM 2 FLAG POLES**
- 20' Aluminum Flagpole
 - Silver Satin Brush Finish
 - Fixed base, Internal Halyard w/ locking door
 - 4" butt diameter

- ITEM 3 TEMPLATES**
- Flagpole template, 0.75" Plywood Qty: 2 total
 - Sign Panel Template, 0.375" Plywood Qty: 2 total



- ITEM 1**
- Brushed Aluminum Letters
 - 0.5" Thick
 - Vertically Brushed Face
 - Sandblasted Edges
 - Concealed, Offset Pin Mounting
 - 10-24 x 2.75" SS Threaded Pins
 - 0.5" Aluminum Sleeves

- ITEM 1.A**
- Painted Aluminum Logo Shapes LEFT
 - 0.375" Thick
 - Painted Face & Edges
 - Concealed, Offset Pin Mounting
 - 10-24 x 2.75" SS Threaded Pins
 - 0.5" Aluminum Sleeves

- ITEM 1.A.A**
- Painted Aluminum Logo Shapes RIGHT
 - 0.375" Thick
 - Painted Face & Edges
 - Concealed, Offset Pin Mounting
 - 10-24 x 2.75" SS Threaded Pins
 - 1" Aluminum Sleeves

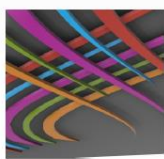
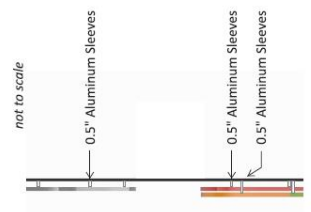

- ITEM 1.B**
- Sign Panel
 - 107"W x 113"H x 0.1875"
 - Painted Face & Edges
 - Matte Lacquer

- ITEM 1.B**
- Sign Panel Mounting Brackets
 - 6" x 4" x 2" x 0.25" L-Channel
 - Painted Face & Edges, Matte Lacquer

- ITEM 1.B.B**
- Sign Panel Horizontal Supports
 - 4" x 2" x 107" x 0.25" Rectangular Tube
 - Painted Face & Edges, Matte Lacquer



Signage Elevation
SCALE 1:30

<p>© BEHREND GROUP INC. These drawings contain confidential proprietary data of the client. It is to be used for the specific project only. No part of these drawings may be reproduced or transmitted in any form or by any means, electronic or mechanical, including photocopying, recording, or by any information storage and retrieval system, without the prior written permission of Behrend Group Inc. All rights reserved. This drawing is the property of Behrend Group Inc. and the responsibility of the client.</p>		<p>CLIENT Metis Crossing</p> <p>PROJECT Highway Signs</p>	<p>SALES gjo</p> <p>DESIGN bt</p> <p>DATE Apr. 29, 2021</p> <p>REVISION 04</p> <p>PAGE 6 of 10</p> <p>FILE NAME 038403.cdr</p>
<p>SHOP DRAWING REVIEW</p> <p><input type="checkbox"/> OK - Proceed Manufacturing</p> <p><input type="checkbox"/> Revisions(s) Required</p> <p>Revised by (signature):</p>		<p>OFFICE USE ONLY: No Design: No Estimate: Estimate Ref:</p>	

2207 51 Avenue NW
Edmonton, Alberta T6A 1L1
P. 780-464-5177 F. 780-467-6516
www.behrendgroup.com

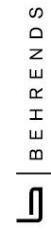

Highway Signs
Technical Details

View the 3D Model in Fusion: <https://a360.co/3rEe1xU>

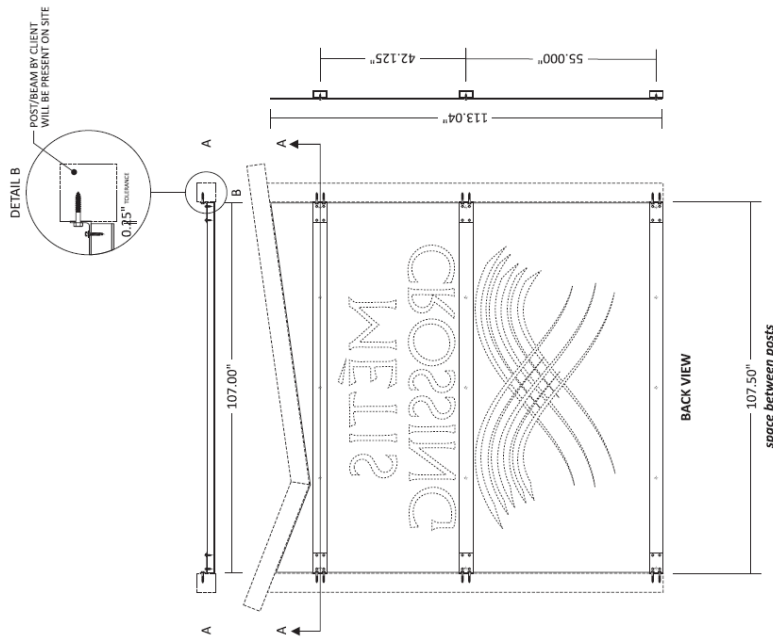

Signage Elevation
SCALE 1:30

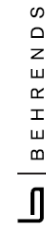

2207-91 Avenue NW
Edmonton, Alberta T6P 1L3
P: 780-464-5177 F: 780-467-6516
www.behrendsgroup.com

© BEHREND S INC. These drawings contain confidential proprietary information. If you are not an authorized recipient, please do not disseminate, copy, reproduce, or use these drawings for any purpose. All rights reserved. No part of these drawings may be reproduced without the written permission of Behrend S Inc. All other rights reserved. Addendum to these drawings are included with the purchase of your project. Addendum revisions are changed over #300-200 each.

SHOP DRAWING REVIEW
 OK - Proceed Manufacturing
 Revision(s) Required
 Revisions by (signature)

CLIENT
Metis Crossing
PROJECT
Highway Signs

SALES
g/fo
DESIGN
bt
DATE
Apr. 29, 2021
REVISION
04
PAGE
7 of 10

OFFICE USE ONLY:
To Design:
Estimate Ref:
FILE NAME
038403.cdr

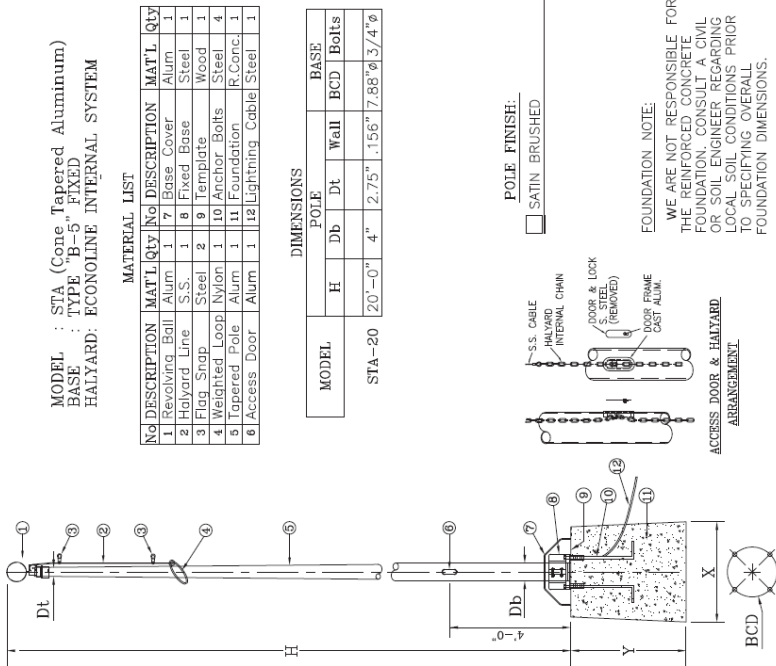

MODEL : STA (Cone Tapered Aluminum)
BASE : TYPE "B-5" FIXED
HALYARD: ECONOLINE INTERNAL SYSTEM

MATERIAL LIST

No	DESCRIPTION	MAT'L	Qty	No	DESCRIPTION	MAT'L	Qty
1	Revolving Ball	Alum	1	7	Base Cover	Alum	1
2	Halvard Line	S.S.	1	8	Fixed Base	Steel	1
3	Flag Snap	Steel	2	9	Template	Wood	1
4	Weighted Loop	Nylon	1	10	Anchor Bolts	Steel	4
5	Tapered Pole	Alum	1	11	Foundation R.Conc.	1	1
6	Access Door	Alum	1	12	Lightning Cable	Steel	1

DIMENSIONS

MODEL	POLE			BASE		
	H	Db	Dt	Wall	BCD	Bolts
STA-20	20'-0"	4"	2.75"	.156"	7.88"Ø	3/4"Ø

POLE FINISH:
 SATIN BRUSHED

FOUNDATION NOTE:
 WE ARE NOT RESPONSIBLE FOR THE REINFORCED CONCRETE FOUNDATION. CONSULT A CIVIL OR SOIL ENGINEER REGARDING LOCAL SOIL CONDITIONS PRIOR TO SPECIFYING OVERALL FOUNDATION DIMENSIONS.
 EWING W.O. No.

Flag Pole Details
SCALE not to scale

Highway Signs
For Color Identification Only



PANTONE 432 C



PANTONE 145 C
PANTONE 377 C
PANTONE 247 C
PANTONE 299 C
PANTONE 200 C

Color Identification
SCALE *not to scale*

2207 01 Avenue NW
Edmonton, Alberta T6P 1L1
P. 780-464-5177 F. 780-467-6516
www.behrendsgroup.com

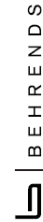

© BEHRENDS GROUP INC. These drawings have confidential proprietary value of BEHRENDS GROUP INC. and are the property of BEHRENDS GROUP INC. No part of these drawings may be reproduced, stored in a retrieval system, or transmitted in any form or by any means, electronic, mechanical, photocopying, recording, or by any information storage and retrieval system, without the prior written permission of BEHRENDS GROUP INC. All rights reserved. BEHRENDS GROUP INC. is not responsible for any errors or omissions in these drawings. All dimensions and notes are in millimeters unless otherwise specified. All dimensions and notes are in millimeters unless otherwise specified. All dimensions and notes are in millimeters unless otherwise specified. All dimensions and notes are in millimeters unless otherwise specified.

SHOP DRAWING REVIEW
 OK - Proceed Manufacturing
 Revision(s) Required
 Reviewed By: (Signature)

Please review drawings carefully. Once all corrections are noted, return drawings to the originator and sign the responsible party of the client. Date signed: _____

CLIENT
Metis Crossing
PROJECT
Highway Signs

SALES gjo
DESIGN bt
DATE Apr. 29, 2021
REVISION 04
PAGE 8 of 10
FILE NAME 038403.cdr

Highway Signs

North Side of Victoria Trail

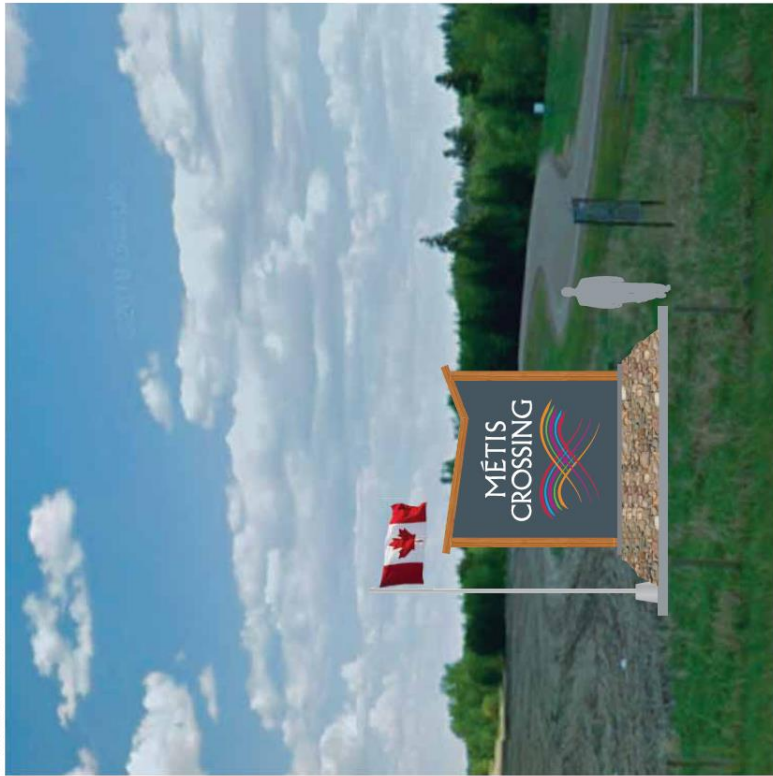

Signage Elevation
SCALE: not to scale

<p>BEHREND'S</p> <p>2207-91 Avenue NW Edmonton, Alberta T6R 1L1 P: 780-467-5177 F: 780-467-6516 www.behrendsgroup.com</p>	<p>SHOP DRAWING REVIEW</p> <p><input type="checkbox"/> OK - Proceed Manufacturing <input type="checkbox"/> Revision(s) Required</p> <p>Reviewed By: [Signature]</p> <p><small>BEHREND'S GROUP INC. shall not be held responsible for any errors or omissions in this drawing. It is the responsibility of the user of this drawing to verify the accuracy of the information contained herein. BEHREND'S GROUP INC. shall not be held responsible for any errors or omissions in this drawing. It is the responsibility of the user of this drawing to verify the accuracy of the information contained herein. BEHREND'S GROUP INC. shall not be held responsible for any errors or omissions in this drawing. It is the responsibility of the user of this drawing to verify the accuracy of the information contained herein.</small></p>	<p>CLIENT Metis Crossing</p> <p>PROJECT Highway Signs</p>	<p>SALES gjo</p> <p>DESIGN bt</p> <p>DATE Apr. 29, 2021</p> <p>REVISION 04</p> <p>PAGE 9 of 10</p> <p>FILE NAME 038403.cdr</p>
--	---	---	--

Highway Signs

Highway 855

Tentative Sign Locations & Orientation
(final positioning by client)



Signage Plan - MAP
SCALE: not to scale (approximately 1:1000)

2207-91 Avenue NW
Edmonton, Alberta T6P 1L1
P: 780-464-5177 F: 780-467-6316
www.behrendsgroup.com



© Behrends Group Inc. All rights reserved. This drawing is the property of Behrends Group Inc. and is not to be reproduced, stored in a retrieval system, or transmitted in any form or by any means, electronic, mechanical, photocopying, recording, or otherwise, without the prior written permission of Behrends Group Inc. This drawing is for informational purposes only and is not to be used for any other purpose. All dimensions are in millimeters unless otherwise specified. This drawing is not to be used for any other purpose. All dimensions are in millimeters unless otherwise specified. This drawing is not to be used for any other purpose. All dimensions are in millimeters unless otherwise specified.

SHOP DRAWING REVIEW
 OK - Proceed Manufacturing
 Revision(s) Required
 Reviewed By: [Signature]

CLIENT
Métis Crossing

PROJECT
Highway Signs

SALES	DESIGN	DATE	REVISION	PAGE
G/O	BT	Apr. 29, 2021	04	10 of 10

OFFICE USE ONLY:
 To Production: 0384403.cdr
 Estimate Ref:

APPENDIX G - GENERAL LOCATION MAP
Development Permit Application No. 026-21
LOT 13, VICTORIA SETTLEMENT
FREESTANDING WELCOME SIGNS (X2)

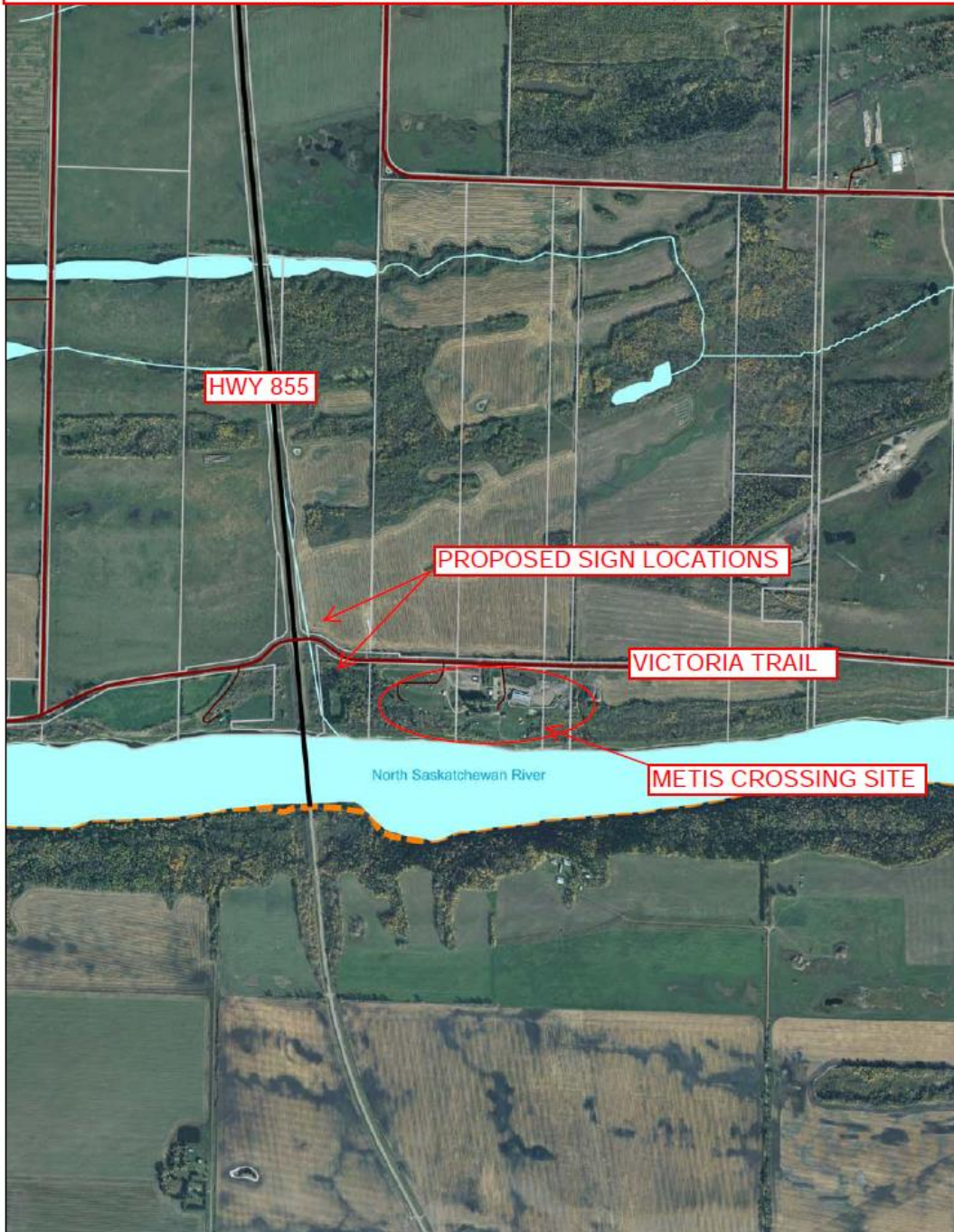

Smoky Lake County

Smoky Lake County

Date Created: 6/10/2021